

United States Court of Appeals for the Federal Circuit

IN RE CUOZZO SPEED TECHNOLOGIES, LLC.

2014-1301

Appeal from the United States Patent and Trademark Office, Patent Trial and Appeal Board in No. IPR2012-00001.

Decided: February 4, 2015

TIMOTHY M. SALMON, Cuozzo Speed Technologies, LLC, of Basking Ridge, New Jersey, argued for appellant. Of counsel on the brief was JOHN R. KASHA, Kasha Law LLC, of North Potomac, Maryland.

NATHAN K. KELLEY, Solicitor, United States Patent and Trademark Office, of Alexandria, Virginia, argued for intervenor. With him on the brief were SCOTT C. WEIDENFELLER and ROBERT J. MCMANUS, Associate Solicitors.

Before NEWMAN, CLEVINGER, and DYK, *Circuit Judges*.

Opinion for the court filed by *Circuit Judge* DYK.

Dissenting opinion filed by *Circuit Judge* NEWMAN.

DYK, *Circuit Judge*.

Cuozzo Speed Technologies (“Cuozzo”) owns U.S. Patent No. 6,778,074 (the “’074 patent”). Garmin International, Inc. and Garmin USA, Inc. (collectively, “Garmin”) petitioned the United States Patent and Trademark Office (“PTO”) for inter partes review (“IPR”) of claims 10, 14, and 17 of the ’074 patent. The PTO granted Garmin’s petition and instituted IPR. The Patent Trial and Appeal Board (the “Board”) timely issued a final decision finding claims 10, 14, and 17 obvious. The Board additionally denied Cuozzo’s motion to amend the ’074 patent by substituting new claims 21, 22, and 23 for claims 10, 14, and 17.

Contrary to Cuozzo’s contention, we hold that we lack jurisdiction to review the PTO’s decision to institute IPR. We affirm the Board’s final determination, finding no error in the Board’s claim construction under the broadest reasonable interpretation standard, the Board’s obviousness determination, and the Board’s denial of Cuozzo’s motion to amend.

BACKGROUND

Cuozzo is the assignee of the ’074 patent, entitled “Speed Limit Indicator and Method for Displaying Speed and the Relevant Speed Limit,” which issued on August 17, 2004. The ’074 patent discloses an interface which displays a vehicle’s current speed as well as the speed limit. In one embodiment, a red filter is superimposed on a white speedometer so that “speeds above the legal speed limit are displayed in red . . . while the legal speeds are displayed in white . . .” *Id.* col. 5 ll. 35–37. A global positioning system (“GPS”) unit tracks the vehicle’s location and identifies the speed limit at that location. The red filter automatically rotates when the speed limit changes, so that the speeds above the speed limit at that location are displayed in red. The patent also states that the speed limit indicator may take the form of a colored liquid crystal display (“LCD”). *Id.* col. 3 ll. 4–6, col. 6 ll.

11–14. In claim 10, the independent claim at issue here, a colored display shows the current speed limit, and the colored display is “integrally attached” to the speedometer. *Id.* col. 7 ll. 10.

Claim 10 recites:

A speed limit indicator comprising:
a global positioning system receiver;
a display controller connected to said global positioning system receiver, wherein said display controller adjusts a colored display in response to signals from said global positioning system receiver to continuously update the delineation of which speed readings are in violation of the speed limit at a vehicle’s present location; and
a speedometer integrally attached to said colored display.

Id. col. 7 ll. 1–10. Claim 14 is addressed to “[t]he speed limit indicator as defined in claim 10, wherein said colored display is a colored filter.” *Id.* col. 7 ll. 23–24. Claim 17 recites: “[t]he speed limit indicator as defined in claim 14, wherein said display controller rotates said colored filter independently of said speedometer to continuously update the delineation of which speed readings are in violation of the speed limit at a vehicle’s present location.” *Id.* col. 8 ll. 5–9.

On September 16, 2012, Garmin filed a petition with the PTO to institute IPR of, *inter alia*, claims 10, 14, and 17 of the ’074 patent. Garmin contended that claim 10 was invalid as anticipated under 35 U.S.C. § 102(e) or as obvious under 35 U.S.C. § 103(a) and that claims 14 and 17 were obvious under § 103(a). The PTO instituted IPR, determining that there was a reasonable likelihood that claims 10, 14, and 17 were obvious under § 103 over (1) U.S. Patent Nos. 6,633,811 (“Aumayer”), 3,980,041 (“Evans”), and 2,711,153 (“Wendt”); and/or (2) German Patent

No. 197 55 470 (“Tegethoff”), U.S. Patent No. 6,515,596 (“Awada”), Evans, and Wendt. Although Garmin’s petition with respect to claim 17 included the grounds on which the PTO instituted review, the petition did not list Evans or Wendt for claim 10 or Wendt for claim 14.

In its subsequent final decision, the Board explained that “[a]n appropriate construction of the term ‘integrally attached’ in independent claim 10 is central to the patentability analysis of claims 10, 14, and 17.” J.A. 7. The Board applied a broadest reasonable interpretation standard and construed the term “integrally attached” as meaning “discrete parts physically joined together as a unit without each part losing its own separate identity.” J.A. 9. The Board found that claims 10, 14, and 17 were unpatentable as obvious under 35 U.S.C. § 103 (1) over Aumayer, Evans, and Wendt; and, alternatively, (2) over Tegethoff, Awada, Evans, and Wendt.

The Board also denied Cuozzo’s motion to amend the patent by replacing claims 10, 14, and 17 with substitute claims 21, 22, and 23. The Board’s denial of the motion to amend centered on proposed claim 21.¹ Claim 21 would have amended the patent to claim “a speedometer integrally attached to [a] colored display, wherein the speedometer comprises a liquid crystal display, and wherein the colored display is the liquid crystal display.” J.A. 357–58. The Board rejected the amendment because (1) substitute claim 21 lacked written description support as required by 35 U.S.C. § 112, and (2) the substitute claims would improperly enlarge the scope of the claims as construed by the Board.

¹ The parties do not separately address claims 22 and 23 and apparently agree that the motion for leave to amend on those claims presents the same issues as claim 21.

Cuozzo appealed. The PTO intervened, and we granted Garmin's motion to withdraw as appellee.² We have jurisdiction to review the Board's final decision under 28 U.S.C. § 1295(a)(4)(A).

DISCUSSION

I

IPRs proceed in two phases. *St. Jude Med., Cardiology Div., Inc. v. Volcano Corp.*, 749 F.3d 1373, 1375–76 (Fed. Cir. 2014). In the first phase, the PTO determines whether to institute IPR. In the second phase, the Board conducts the IPR proceeding and issues a final decision. *Id.*

Cuozzo argues that the PTO improperly instituted IPR on claims 10 and 14 because the PTO relied on prior art that Garmin did not identify in its petition as grounds for IPR as to those two claims (though the prior art in question was identified with respect to claim 17). Under the statute, any petition for IPR must “identif[y] . . . with particularity . . . the grounds on which the challenge to each claim is based . . .” 35 U.S.C. § 312(a)(3). Cuozzo argues that the PTO may only institute IPR based on grounds identified in the petition because “[t]he Director may not authorize an inter partes review to be instituted unless the Director determines that the information presented in the petition . . . and any response . . . shows that there is a reasonable likelihood that the petitioner would prevail . . .” *Id.* § 314(a).

Section 314(d) is entitled “No appeal” and provides that “[t]he determination by the Director whether to

² Garmin filed a motion to withdraw because it agreed not to participate in any appeal of the IPR written decision as part of a settlement agreement with Cuozzo.

institute an inter partes review under this section shall be final and nonappealable.” 35 U.S.C. § 314(d). The PTO argues that § 314(d) precludes review of a determination to institute IPR. Cuozzo argues that § 314(d) does not completely preclude review of the decision to institute IPR, but instead merely postpones review of the PTO’s authority until after the issuance of a final decision by the Board.

We have previously addressed § 314(d) and have held that it precludes interlocutory review of decisions whether to institute IPR. In *St. Jude*, we characterized § 314(d) as a “broadly worded bar on appeal” and held that § 314(d) “certainly bars” interlocutory review of the PTO’s denial of a petition for IPR. 749 F.3d at 1375–76. This result was supported by § 319, which “authorizes appeals to this court only from ‘the final written decision of the [Board]’” *Id.* at 1375 (quoting 35 U.S.C. § 319) (alteration in original). Similarly, the bar to interlocutory review is supported by 35 U.S.C. § 141(c), which “authorizes appeal only by ‘a party to an inter partes review . . . who is dissatisfied with the final written decision of the [Board] under section 318(a).’” *Id.* (quoting 35 U.S.C. § 141(c)) (alterations in original). But while we stated that § 314 “may well preclude all review by any route,” we did not decide the issue. *Id.* at 1376.

We conclude that § 314(d) prohibits review of the decision to institute IPR even after a final decision. On its face, the provision is not directed to precluding review only before a final decision. It is written to exclude all review of the decision whether to institute review. Section 314(d) provides that the decision is both “nonappealable” and “final,” i.e., not subject to further review. 35 U.S.C. § 314(d). A declaration that the decision to institute is “final” cannot reasonably be interpreted as postponing review until after issuance of a final decision on patentability. Moreover, given that § 319 and § 141(c) already limit appeals to appeals from final decisions, § 314(d)

would have been unnecessary to preclude non-final review of institution decisions. Because § 314(d) is unnecessary to limit interlocutory appeals, it must be read to bar review of all institution decisions, even after the Board issues a final decision. Nor does the IPR statute expressly limit the Board's authority at the final decision stage to the grounds alleged in the IPR petition. It simply authorizes the Board to issue "a final written decision with respect to the patentability of any patent claim challenged by the petitioner and any new claim added under section 316(d)." 35 U.S.C. § 318(a).

Our decision in *In re Hiniker Co.*, 150 F.3d 1362, 1367 (Fed. Cir. 1998), confirms the correctness of the PTO's position here. There, even absent a provision comparable to § 314(d),³ we held that a flawed decision to institute reexamination under 35 U.S.C. § 303 was not a basis for setting aside a final decision. *Hiniker*, 150 F.3d at 1367. Under the statute at issue in *Hiniker*, reexamination could only be instituted if the Commissioner determined that there was "a substantial new question of patentability," i.e., new prior art not considered by the examiner. 35 U.S.C. § 303(a) (1994). In *Hiniker*, the PTO instituted reexamination based on prior art considered in the original examination (Howard). *Hiniker*, 150 F.3d at 1365. But the PTO's final decision relied on East (which had not been before the examiner in the initial examination) in finding the claims invalid. *Id.* at 1366. We held that our jurisdiction was only "over *Hiniker's* appeal from the [final] decision of the Board." *Id.* at 1367. While the final

³ Unlike § 314, the reexamination statute only provides that "[a] determination by the Commissioner . . . that *no* substantial new question of patentability has been raised will be final and nonappealable." 35 U.S.C. § 303(c) (1994) (emphasis added).

decision would have been subject to reversal if it had improperly relied only on prior art presented to the examiner,⁴ any error in instituting reexamination based on the Howard reference was “washed clean during the reexamination proceeding,” which relied on new art. *Id.* The fact that the petition was defective is irrelevant because a proper petition could have been drafted. The same is even clearer here, where § 314(d) explicitly provides that there is no appeal available of a decision to institute. There was no bar here to finding claims 10 and 14 unpatentable based on the Evans and/or Wendt references. The failure to cite those references in the petition provides no ground for setting aside the final decision.

Cuozzo argues that Congress would not have intended to allow the PTO to institute IPR in direct contravention of the statute, for example, on grounds of prior public use where the IPR statute permits petitions only on the basis of “prior art consisting of patents or printed publications.” 35 U.S.C. § 311. The answer is that mandamus may be available to challenge the PTO’s decision to grant a petition to institute IPR after the Board’s final decision in situations where the PTO has clearly and indisputably exceeded its authority.

The PTO argues that our previous decisions preclude mandamus. In *In re Dominion Dealer Solutions, LLC*, 749 F.3d 1379, 1381 (Fed. Cir. 2014), we held that mandamus relief was not available to challenge the denial of a petition for IPR. Given the statutory scheme, there was no

⁴ See *In re Portola Packaging, Inc.*, 110 F.3d 786, 789, *superseded by statute as recognized by In re NTP, Inc.*, 654 F.3d 1268, 1277 (Fed. Cir. 2011); *In re Recreative Techs. Corp.*, 83 F.3d 1394 (Fed. Cir. 1996). Congress subsequently amended the statute to provide for consideration of prior art before the examiner. 35 U.S.C. § 303.

“clear and indisputable right’ to challenge a non-institution decision directly in this court,” as required for mandamus. *Id.* And in *In re Procter & Gamble Co.*, 749 F.3d 1376, 1378–79 (Fed. Cir. 2014), we held that mandamus was not available to provide immediate review of a decision to institute IPR. There was no “clear and indisputable right to this court’s immediate review of a decision to institute an inter partes review, as would be needed for mandamus relief.” *Id.* at 1379. Furthermore, that “[wa]s not one of the rare situations in which irreparable interim harm c[ould] justify mandamus, which is unavailable simply to relieve [the patentee] of the burden of going through the inter partes review.” *Id.* (citation omitted). However, we did not decide the question of whether the decision to institute review is reviewable by mandamus after the Board issues a final decision or whether such review is precluded by § 314(d). *Id.* Nor do we do so now.

Even if § 314 does not bar mandamus after a final decision, at least “three conditions must be satisfied before [a writ of mandamus] may issue.” *Cheney v. U.S. Dist. Court for the D.C.*, 542 U.S. 367, 380 (2004). “First, ‘the party seeking issuance of the writ [must] have no other adequate means to attain the relief he desires.’” *Id.* (quoting *Kerr v. U.S. Dist. Court for the N. Dist. of Cal.*, 426 U.S. 394, 403 (1976) (alteration in original)). That condition appears to be satisfied since review by appeal is unavailable. “Second, the petitioner must satisfy ‘the burden of showing that his right to issuance of the writ is clear and indisputable.’” *Id.* at 381 (internal quotations, citation, and alterations omitted). “Third, the issuing court, in the exercise of its discretion, must be satisfied that the writ is appropriate under the circumstances.” *Id.* (citation omitted).

Here, Cuozzo has not filed a mandamus petition, but even if we were to treat its appeal as a request for mandamus,⁵ the situation here is far from satisfying the clear-and-indisputable requirement for mandamus. It is not clear that IPR is strictly limited to the grounds asserted in the petition. The PTO urges that instituting IPR of claims 10 and 14 based on the grounds for claim 17 was proper because claim 17 depends from claim 14, which depends from claim 10. Any grounds which would invalidate claim 17 would by necessary implication also invalidate claims 10 and 14. *See Callaway Golf Co. v. Acushnet Co.*, 576 F.3d 1331, 1344 (Fed. Cir. 2009) (“A broader independent claim cannot be nonobvious where a dependent claim stemming from that independent claim is invalid for obviousness.”). The PTO argues that Garmin implicitly asserted that claims 10 and 14 were unpatentable when it asserted that claim 17 was unpatentable. Whether or not the PTO is correct in these aspects, it is at least beyond dispute there is no clear and indisputable right that precludes institution of the IPR proceeding. We need not decide whether mandamus to review institution of IPR after a final decision is available in other circumstances.

II

Cuozzo contends in addition that the Board erred in finding the claims obvious, arguing initially that the

⁵ *See* 16 Charles A. Wright, Arthur R. Miller & Edward H. Cooper, *Federal Practice and Procedure* § 3932.1 (3d ed. 2012) (“Many cases illustrate the seemingly converse proposition that . . . an appeal can substitute for a writ in the sense that an attempted appeal from an order that is nonappealable can be treated as a petition for a writ.” (citations omitted)).

IN RE CUOZZO SPEED TECHNOLOGIES, LLC

11

Board should not have applied the broadest reasonable interpretation standard in claim construction.

A

The America Invents Act (“AIA”) created IPR, but the statute on its face does not resolve the issue of whether the broadest reasonable interpretation standard is appropriate in IPRs; it is silent on that issue. However, the statute conveys rulemaking authority to the PTO. It provides that “[t]he Director shall prescribe regulations,” *inter alia*, “setting forth the standards for the showing of sufficient grounds to institute . . . review,” and “establishing and governing inter partes review . . . and the relationship of such review to other proceedings” 35 U.S.C. § 316(a)(2), (a)(4). Pursuant to this authority, the PTO has promulgated 37 C.F.R. § 42.100(b), which provides that “[a] claim in an unexpired patent shall be given its broadest reasonable construction in light of the specification of the patent in which it appears.” 37 C.F.R. § 42.100(b). Cuozzo argues that the PTO lacked authority to promulgate § 42.100(b) and that the broadest reasonable interpretation standard is inappropriate in an adjudicatory IPR proceeding. The PTO argues that 35 U.S.C. § 316 provides the necessary authority to the PTO to promulgate § 42.100(b) and that the broadest reasonable interpretation is appropriately applied in the IPR context.

1

Before addressing the scope of the PTO’s rulemaking authority, we consider the history of the broadest reasonable interpretation standard and the bearing of that history on the interpretation of the IPR statute. No section of the patent statute explicitly provides that the broadest reasonable interpretation standard shall be used in any PTO proceedings.

Nonetheless, the broadest reasonable interpretation standard has been applied by the PTO and its predecessor

for more than 100 years in various types of PTO proceedings. A 1906 PTO decision explained, “[n]o better method of construing claims is perceived than to give them in each case the broadest interpretation which they will support without straining the language in which they are couched.” *Podlesak v. McInnerney*, 1906 Dec. Comm’r Pat. 265, 258. For more than a century, courts have approved that standard. *See, e.g., Miel v. Young*, 29 App. D.C. 481, 484 (D.C. Cir. 1907) (“This claim should be given the broadest interpretation which it will support”); *In re Rambus, Inc.*, 753 F.3d 1253, 1255 (Fed. Cir. 2014) (“Claims are generally given their ‘broadest reasonable interpretation’ consistent with the specification during reexamination.” (citation omitted)); *In re Am. Acad. of Sci. Tech Ctr.*, 367 F.3d 1359, 1364 (Fed. Cir. 2004) (“Giving claims their broadest reasonable construction ‘serves the public interest by reducing the possibility that claims, finally allowed, will be given broader scope than is justified.’” (quoting *In re Yamamoto*, 740 F.2d 1569, 1571 (Fed. Cir. 1984))); *In re Morris*, 127 F.3d 1048, 1054 (Fed. Cir. 1997) (“[W]e reject appellants’ invitation to construe either of the cases cited by appellants so as to overrule, *sub silentio*, decades old case law. . . . It would be inconsistent with the role assigned to the PTO in issuing a patent to require it to interpret claims in the same manner as judges who, post-issuance, operate under the assumption the patent is valid. The process of patent prosecution is an interactive one.”); *In re Carr*, 297 F. 542, 544 (D.C. Cir. 1924) (“For this reason we have uniformly ruled that claims will be given the broadest interpretation of which they reasonably are susceptible. This rule is a reasonable one, and tends not only to protect the real invention, but to prevent needless litigation after the patent has issued.”); *In re Kebrich*, 201 F.2d 951, 954 (CCPA 1953) (“[I]t is . . . well settled that . . . the tribunals [of the PTO] and the reviewing courts in the initial consideration of patentability will give claims the broadest interpretation which, within reason, may be applied.”).

This court has approved of the broadest reasonable interpretation standard in a variety of proceedings, including initial examinations, interferences, and post-grant proceedings such as reissues and reexaminations. Indeed, that standard has been applied in every PTO proceeding involving unexpired patents.⁶ In doing so, we have cited the long history of the PTO's giving claims their broadest reasonable construction. *See, e.g., Yamamoto*, 740 F.2d at 1571–72 (reexaminations); *In re Reuter*, 670 F.2d 1015, 1019 (CCPA 1981) (reissues); *Reese v. Hurst*, 661 F.2d 1222, 1236 (CCPA 1981) (interferences); *In re Prater*, 415 F.2d 1393, 1404–05 (CCPA 1969) (examinations). Applying the broadest reasonable interpretation standard “reduce[s] the possibility that, after the patent is granted, the claims may be interpreted as giving broader coverage than is justified.” *Reuter*, 670 F.2d at 1015 (quoting *Prater*, 415 F.2d at 1404–05).

There is no indication that the AIA was designed to change the claim construction standard that the PTO has applied for more than 100 years. Congress is presumed to legislate against the background of existing law where Congress in enacting legislation is aware of the prevailing rule. As we held in *GPX International Tire Corp. v. United States*, “the principle of legislative ratification is well

⁶ The claims of an expired patent are the one exception where the broadest reasonable interpretation is not used because the patentee is unable to amend the claims. *Rambus*, 753 F.3d at 1256 (“If, as is the case here, a reexamination involves claims of an expired patent, a patentee is unable to make claim amendments and the PTO applies the claim construction principles outlined by this court in *Phillips v. AWH Corp.*, 415 F.3d 1303 (Fed. Cir. 2005).” (citations omitted)).

established. In the case of a widely known judicial decision or agency practice, Congress is presumed to be aware of an administrative or judicial interpretation of a statute and to adopt that interpretation when it re-enacts a statute without change.” 666 F.3d 732, 739 (Fed. Cir. 2011) (internal quotation marks and citations omitted), *superseded in part by statute as recognized in* 678 F.3d 1308 (Fed. Cir. 2012); *Astoria Fed. Sav. & Loan Ass’n v. Solimino*, 501 U.S. 108, 110 (1991); *Procter & Gamble Co. v. Kraft Foods Global*, 549 F.3d 842, 848–49 (Fed. Cir. 2008) (improper to presume that congress would alter the backdrop of existing law *sub silentio*).

Here, Congress in enacting the AIA was well aware that the broadest reasonable interpretation standard was the prevailing rule. *See* 157 Cong. Rec. S1375 (daily ed. Mar. 8, 2011) (statement of Sen. Kyl) (allowing written statements to be considered in inter partes review “should . . . allow the Office to identify inconsistent statements made about claim scope—for example, cases where a patent owner successfully advocated a claim scope in district court that is broader than the ‘broadest reasonable construction’ that he now urges in an inter partes review”). It can therefore be inferred that Congress impliedly adopted the existing rule of adopting the broadest reasonable construction.

Cuozzo argues that judicial or congressional approval of the broadest reasonable interpretation standard for other proceedings is irrelevant here because the earlier judicial decisions relied on the availability of amendment, and the AIA limits amendments in IPR proceedings.⁷

⁷ *See, e.g., Yamamoto*, 740 F.2d at 1571–72 (“An applicant’s *ability to amend his claims* to avoid cited prior art distinguishes proceedings before the PTO from pro-

But IPR proceedings are not materially different in that respect. Section 316(d)(1) provides that a patentee may file one motion to amend in order to “[c]ancel any challenged patent claim” or “[f]or each challenged claim, propose a reasonable number of substitute claims,” 35 U.S.C. § 316(d)(1), though “[a]n amendment . . . may not enlarge the scope of the claims of the patent or introduce new matter,” *id.* § 316(d)(3). The PTO regulations provide that “[a] patent owner may file one motion to amend a patent, but only after conferring with the Board.” 37 C.F.R. § 42.221(a). “The presumption is that only one substitute claim would be needed to replace each challenged claim, and it may be rebutted by a demonstration of need.” *Id.* § 42.221(a)(3). The statute also provides that “[a]dditional motions to amend may be permitted upon the joint request of the petitioner and the patent owner . . .” 35 U.S.C. § 316(d)(2). “A motion to amend may be denied where” the amendment either “does not respond to

ceedings in federal district courts on issued patents.” (emphasis added)); *Reuter*, 670 F.2d at 1019 (“It is well settled that claims before the PTO are to be given their broadest reasonable interpretation consistent with the specification during the examination of a patent application since the applicant may then amend his claims . . .” (internal quotation marks omitted)); *Prater*, 415 F.2d at 1404–05 (“[T]his court has consistently taken the tack that claims yet unpatented are to be given the broadest reasonable interpretation consistent with the specification during the examination of a patent application since the applicant may then amend his claims . . .”); *see also, e.g., In re Skvorecz*, 580 F.3d 1262, 1267 (Fed. Cir. 2009) (“As explained in the Manual of Patent Examining Procedure (MPEP) . . . , Applicant always has the opportunity to amend the claims during prosecution . . .” (internal quotation marks omitted)).

a ground of unpatentability involved in the [IPR] trial” or “seeks to enlarge the scope of the claims of the patent or introduce new subject matter.” 37 C.F.R. § 42.221(a)(2).

Although the opportunity to amend is cabined in the IPR setting, it is thus nonetheless available. The fact that the patent owner may be limited to a single amendment, may not broaden the claims, and must address the ground of unpatentability is not a material difference. Nor is the fact that IPR may be said to be adjudicatory rather than an examination. Interference proceedings are also in some sense adjudicatory, *see Brand v. Miller*, 487 F.3d 862, 867–68 (Fed. Cir. 2007) (characterizing interference proceedings as adjudicatory and holding that the Board’s decision be reviewed on the record), yet the broadest reasonable interpretation standard applies, *see Genentech, Inc. v. Chiron Corp.*, 112 F.3d 495, 500 (Fed. Cir. 1997) (“In the absence of ambiguity, it is fundamental that the language of a count should be given the broadest reasonable interpretation it will support . . .” (quoting *In re Baxter*, 656 F.2d 679, 686 (CCPA 1981))). In any event, Congress in enacting the AIA was aware of these differences in terms of amendments and adjudication and did not provide for a different standard than the broadest reasonable interpretation standard. We conclude that Congress implicitly adopted the broadest reasonable interpretation standard in enacting the AIA.

Even if we were to conclude that Congress did not adopt the broadest reasonable interpretation standard in enacting the AIA, § 316 provides authority to the PTO to conduct rulemaking. Although we have previously held that 35 U.S.C. § 2(b) does not grant substantive rulemak-

ing authority to the PTO,⁸ *Cooper Techs. Co. v. Dudas*, 536 F.3d 1330, 1335–36 (Fed. Cir. 2008), the AIA granted new rulemaking authority to the PTO. Section 316(a)(2) provides that the PTO shall establish regulations “setting forth the standards for the showing of sufficient grounds to institute a review . . .” 35 U.S.C. § 316(a)(2). Section 316(a)(4) further provides the PTO with authority for “establishing and governing inter partes review under this chapter and the relationship of such review to other proceedings under this title.” *Id.* § 316(a)(4). These provisions expressly provide the PTO with authority to establish regulations setting the “standards” for instituting

⁸ Section 2 provides, in relevant part:

(b) Specific Powers.—the Office—

. . .

(2) may establish regulations, not inconsistent with law, which

(A) shall govern the conduct of proceedings in the Office;

(B) shall be made in accordance with section 553 of title 5;

(C) shall facilitate and expedite the processing of patent applications, particularly those which can be filed, stored, processed, searched, and retrieved electronically, subject to the provisions of section 122 relating to the confidential status of applications[.]

35 U.S.C. § 2(b)(2)(A)–(C).

review and regulating IPR proceedings. The broadest reasonable interpretation standard affects both the PTO's determination of whether to institute IPR proceedings and the proceedings after institution and is within the PTO's authority under the statute.

Because Congress authorized the PTO to prescribe regulations, the validity of the regulation is analyzed according to the familiar *Chevron* framework. See *United States v. Mead Corp.*, 533 U.S. 218, 226–27 (2001); *Wilder v. Merit Sys. Prot. Bd.*, 675 F.3d 1319, 1322 (Fed. Cir. 2012). Under *Chevron*, the first question is “whether Congress has directly spoken to the precise question at issue.” *Chevron, U.S.A. v. Natural Res. Def. Council, Inc.*, 467 U.S. 837, 842 (1984); accord *Cooper*, 536 F.3d at 1337 (quoting *Hawkins v. United States*, 469 F.3d 993, 1000 (Fed. Cir. 2006)). If the statute is ambiguous, the second question is “whether the agency's interpretation is based on a permissible construction of the statutory language at issue.” *Cooper*, 536 F.3d at 1338 (quoting *Hawkins*, 469 F.3d at 1000).

In the text of the IPR statute, Congress was silent on the subject of claim construction standards, and, if we assume *arguendo* that it did not adopt the broadest reasonable interpretation standard, step one of *Chevron* is satisfied. We proceed to step two of the *Chevron* analysis. The regulation here presents a reasonable interpretation of the statute. The PTO has long applied the broadest reasonable interpretation standard in other proceedings, suggesting that a broadest reasonable interpretation standard is appropriate in IPRs. As discussed above, the policy rationales for the broadest reasonable interpretation standard in other examination proceedings also apply in the IPR context. The statute also provides for the PTO to exercise discretion to consolidate an IPR with another proceeding before the PTO. See 35 U.S.C. § 315(d). The possibility of consolidating multiple types of proceedings suggests a single claim construction standard across

proceedings is appropriate. 37 C.F.R. § 42.221(a) reflects a permissible construction of the statutory language in § 316(a). Even if the broadest reasonable interpretation standard were not incorporated into the IPR provisions of the statute, the standard was properly adopted by PTO regulation.

B

The second issue is whether the Board here properly construed the claims under the broadest reasonable interpretation standard. We review the Board's claim construction according to the Supreme Court's decision in *Teva Pharmaceuticals U.S.A., Inc. v. Sandoz, Inc.*, 135 S. Ct. 831, 841 (2015). We review underlying factual determinations concerning extrinsic evidence for substantial evidence and the ultimate construction of the claim de novo. *See id.* Because there is no issue here as to extrinsic evidence, we review the claim construction de novo.

Claim 10 includes the following limitation: "a speedometer integrally attached to said colored display." '074 patent col. 7 l. 10. Cuozzo argues that the board improperly construed the phrase "integrally attached." The Board construed "integrally attached" as meaning "discrete parts physically joined together as a unit without each part losing its own separate identity." J.A. 9. Cuozzo contends that the correct construction of "integrally attached" should be broader—"joined or combined to work as a complete unit." Appellant's Br. 33. Before the Board, Cuozzo stated that its construction would cover "a display that both functionally and structurally integrates the speedometer and the colored display, such that there only is a single display." J.A. 10. Cuozzo argues that the Board's claim construction improperly excludes a single-LCD embodiment of the invention wherein the speedometer and the speed limit indicator are on the same LCD.

The phrase "integrally attached" was not included in either the specification or the claims as originally filed.

The phrase was introduced by an amendment to claim 10 to overcome a rejection that the claim was anticipated under § 102(e) by Awada.⁹

We see no error in the Board's interpretation. The word "attached" must be given some meaning. As the Board explained, it would "be illogical to regard one unit as being 'attached' to itself." J.A. 9. The specification further supports the Board's construction that the speedometer and the speed limit are independent—it repeatedly refers to a speed limit indicator independent of any speedometer and states that "the present invention essentially comprises a speed limit indicator comprising a speed limit display and an attached speedometer." '074

⁹ Claim 10 of the '074 patent corresponds to the claim numbered as claim 11 during patent prosecution.

Prior to amendment, claim 10 included the limitation: "a speedometer attached to said speed limit display." J.A. 100. Cuozzo's proposed amendment to that limitation recited "a speedometer integrally attached to said colored display." *Id.* In proposing the amendment, Cuozzo argued that the amendment overcame Awada because

"[t]he cited Awada (6,515,596) lacks a speedometer integrally attached to the speed limit display The vehicle's driver is forced to look in two separate locations and then mentally compare the speed limit with his vehicle's speed to determine how close he is to speeding if he is not already doing so sufficiently to activate the light and/or tone. . . . In contrast, the present invention provides an integrated display allowing the driver to immediately ascertain both his speed and its relation to the prevailing speed limit."

J.A. 104–105.

patent col. 2 ll. 52–54. The Board did not err in its claim construction.

C

The third question is whether claims 10, 14, and 17 were obvious. We review the Board’s factual findings for substantial evidence and review its legal conclusions de novo. *In re Baxter Int’l, Inc.*, 678 F.3d 1357, 1361 (Fed. Cir. 2012). The ultimate determination of obviousness under § 103 is a question of law based on underlying factual findings. *Id.* (citing *Graham v. John Deere Co.*, 383 U.S. 1, 17–18 (1966)). What a reference teaches and the differences between the claimed invention and the prior art are questions of fact which we review for substantial evidence. *Id.* (citations omitted). Cuozzo states that, “[f]or the purposes of this appeal, claims 10, 14, and 17 rise and fall together.” Appellant Br. 17 n.1. Therefore, we analyze only claim 10.

Even under its own claim construction, Cuozzo agrees that the disclosed mechanical embodiment with a red colored filter is within the claim scope. In the analog embodiment disclosed in the specification, a red filter is superimposed on a white speedometer so that “speeds above the legal speed limit are displayed in red . . . while the legal speeds are displayed in white . . .” ’074 patent col. 5 ll. 35–37. A GPS unit tracks the vehicle’s location, and the speed limit at that location is determined. The red filter automatically rotates in response so that speeds over the legal speed limit are displayed in red.

It is a “long-established rule that ‘claims which are broad enough to read on obvious subject matter are unpatentable even though they also read on nonobvious subject matter.’” *Muniauction, Inc. v. Thomson Corp.*, 532 F.3d 1318, 1328 n.4 (quoting *In re Lintner*, 458 F.2d 1013, 1015 (CCPA 1972)) (internal alterations omitted). Thus if the mechanical embodiment is obvious, claim 10 is obvious. The Board determined that the mechanical embodi-

ment was obvious over Aumayer, Evans, and Wendt. We see no error in that determination.

Aumayer discloses a display which shows a vehicle's speed and indicates the current speed limit by highlighting the appropriate mark on a speed scale or by producing a scale mark of a different length or color. Aumayer col. 1 l. 12, col. 5 ll. 19–31. Aumayer further teaches obtaining the current location of a vehicle from an on-board GPS, *id.* Abstract, col. 4 ll. 41–45, and “updating the speed limit data stored in the vehicle by means of a radio connection . . . by means of a data carrier,” *id.* col. 2 ll. 54–57. Figure 2a provides an illustration:

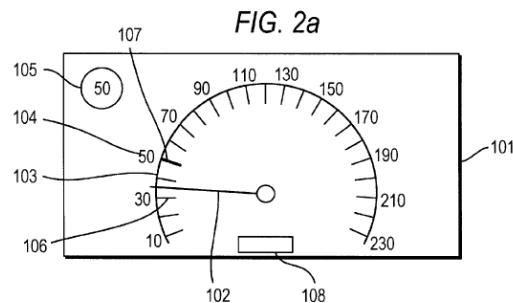

Element 105 displays a maximum speed limit, and element 107 highlights this same speed limit on the speed scale. The pointer designated by element 102 displays the vehicle's current speed.

Evans discloses a transparent plate that “bears warning indicia, for example, a special color and/or a plurality of marks, spaces, ridges, etc. so that when the speedometer dial is viewed through it, a portion of the dial representing speeds in excess of a predetermined limit are demarked by the warning indicia.” Evans col. 2 ll. 3–8. The plate is generally fixed but can be removed and recut and/or repositioned in order to extend over a different range of numbers on the dial. Figure 3 is illustrative:

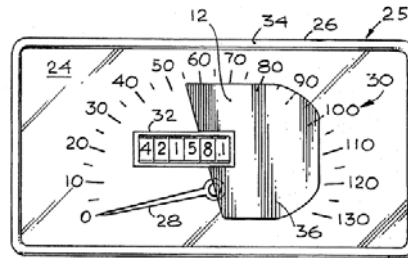
**Fig. 3**

Wendt discloses a speed limit indicator which is attachable by a suction cup to the cover of a speedometer. The indicator has a pointer which is rotatable to indicate the current speed limit.

Cuozzo argues that Aumayer, Evans, and Wendt do not disclose “continuously updat[ing] the delineation of which speed readings are in violation of the speed limit at a vehicle's present location,” as required by claim 10. '074 patent col. 7 ll. 6–9. In particular, Cuozzo contends that Aumayer discloses updating speed limits associated with a region and not with a geographic position determined by the GPS locating device. The Board found that “it is indisputable that Aumayer displays the speed limit for the current location of a vehicle as determined by a GPS receiver, and not merely the speed limit for a certain class of road in a given region without any connection to the vehicle's current location.” J.A. 34. The Board's finding is supported by substantial evidence.

Cuozzo also argues that there is no motivation to combine Aumayer, Evans, and Wendt because Aumayer is an automatic device while Evans and Wendt are manual devices. However, “[a]pplying modern electronics to older mechanical devices has been commonplace in recent years.” *Leapfrog Enters., Inc. v. Fisher-Price, Inc.*, 485 F.3d 1157, 1161 (Fed. Cir. 2007). It would have been obvious to combine Aumayer, Evans, and Wendt to arrive

at the analog embodiment. Cuozzo does not contend that any secondary considerations argue against a finding of obviousness.

Claim 10 would have been obvious over Aumayer, Evans, and Wendt because it encompasses the analog embodiment of the invention discussed in the specification. We need not address whether claim 10 is also obvious over Tegethoff, Awada, Evans, and Wendt, as the Board also concluded.

D

Finally, we consider whether the Board properly denied Cuozzo's motion for leave to amend, finding that Cuozzo's substitute claims would enlarge the scope of the patent. Cuozzo moved to substitute claim 10 with the following substitute claim 21:

A speed limit indicator comprising:
a global positioning system receiver determining a vehicle's present location, a vehicle's present speed and a speed limit at the vehicle's present location;
a display controller connected to said global positioning system receiver, wherein said display controller adjusts a colored display in response to signals indicative of the speed limit at the vehicle's present location from said global positioning system receiver to continuously update the delineation of which speed readings determined by the global positioning system receiver are in violation of the speed limit at the vehicle's present location; and
a speedometer integrally attached to said colored display,
wherein the speedometer comprises a liquid crystal display, and
wherein the colored display is the liquid crystal display.

J.A. 357–58.

The statute and PTO regulation bar amendments which would broaden the scope of the claims. 35 U.S.C. § 316(d)(3); 37 C.F.R. § 42.221(a)(2)(ii). In the past, we have construed this requirement in the context of reissues and reexaminations. In both contexts, we have applied the test that a claim “is broader in scope than the original claims if it contains within its scope any conceivable apparatus or process which would not have infringed the original patent.” *Tillotson, Ltd. v. Walbro Corp.*, 831 F.2d 1033, 1037 n.2 (Fed. Cir. 1987) (in the reissue context); *see In re Freeman*, 30 F.3d 1459, 1464 (Fed. Cir. 1994) (quoting *Tillotson*, 831 F.2d at 1037 n.2) (in the reexamination context). The same test applies in the context of IPRs. Therefore, we inquire whether Cuozzo’s proposed substitute claims would encompass any apparatus or process that would not have been covered by the original claims.¹⁰ The Board held that claim 21 was broadening because it would encompass a single-LCD embodiment wherein both the speedometer and the colored display are LCDs, which was not within the original claims. Cuozzo argues that the proposed claims were not broadening and instead copied limitations from two dependent claims in the patent.

¹⁰ Cuozzo argues that its substitute claim is narrowing because it is limited to the single-LCD embodiment and no longer would encompass the mechanical embodiment. This argument misstates the test for broadening. “[A] claim is broadened if it is broader in any respect than the original claim, even though it may be narrowed in other respects.” *In re Rogoff*, 261 F.2d 601, 603 (C.C.P.A. 1958); *see also Senju Pharm. Co., Ltd. v. Apotex Inc.*, 746 F.3d 1344, 1352 (Fed. Cir. 2014).

Based on the proper construction of the phrase “integrally attached,” we agree with the PTO that Cuozzo’s proposed amendment is broadening. Cuozzo itself argues that the motion to amend was denied solely because of the PTO’s interpretation of “integrally attached,” and argues only that a remand is necessary if we were to reverse the Board’s claim construction (which we have not done). Cuozzo admits that the Board’s construction of “integrally attached” “excludes the single LCD embodiment of the invention in which the speedometer includes an LCD that is the colored display.” Appellant Br. 33. Proposed claim 21 recites “a speedometer integrally attached to said colored display, wherein the speedometer comprises a liquid crystal display, and wherein the colored display is *the* liquid crystal display.” J.A. 358 (emphasis added). The word “the,” emphasized in the quoted language above, requires a single-LCD embodiment that includes both the speedometer and the colored display in one LCD. Because proposed claim 21 would encompass an embodiment not encompassed by claim 10, it is broadening, and the motion to amend was properly denied.

AFFIRMED

United States Court of Appeals for the Federal Circuit

IN RE CUOZZO SPEED TECHNOLOGIES, LLC.

2014-1301

Appeal from the United States Patent and Trademark Office, Patent Trial and Appeal Board in No. IPR2012-00001.

NEWMAN, *Circuit Judge*, dissenting.

I respectfully dissent, for several of the panel majority's rulings are contrary to the legislative purpose of the Leahy-Smith America Invents Act, Pub. L. No. 112-29, 125 Stat. 284 (2011) (effective September 16, 2012).

The America Invents Act established a new Inter Partes Review system for the purpose of "providing quick and cost effective alternatives to litigation." H.R. Rep. No. 112-98, pt. 1, at 48 (2011). This purpose was achieved by providing a new adjudicatory proceeding in the administrative agency, the Patent and Trademark Office in the Department of Commerce, whereby a newly formed Patent Trial and Appeal Board (PTAB) serves as a surrogate for district court litigation of patent validity. The goal is improved service to technology-based innovation, and thus to the nation. The panel majority thwarts the statutory plan in several ways.

First, the panel majority holds that the PTAB, in conducting its adversarial proceedings, need not and should

not apply the same legal and evidentiary standards as would apply in the district court. Instead, the panel majority authorizes and requires treating the claims of an issued patent in the same way as pending claims in the patent application stage, where claims are subject to the “broadest reasonable interpretation” examination protocol. The panel majority thus precludes achieving review of patent validity in Inter Partes Review comparable to that of the district courts, where validity is determined based on the correct claim construction, not an artificially “broadest” construction.

This court has approved the use of “broadest reasonable interpretation” as an expedient in examination and reexamination, but our approval was based on the unfettered opportunity to amend in those proceedings. That opportunity is not present in Inter Partes Review; amendment of claims requires permission, and since the inception of Inter Partes Review, motions to amend have been granted in only two cases, although many have been requested.¹

The purpose of Inter Partes Review is to “convert” inter partes reexamination “from an examinational proceeding to an adjudicative proceeding.” H.R. Rep. No. 112-98, pt.1, at 46. *See also* 157 Cong. Rec. S1111 (Mar. 2, 2011)

¹ *See* Andrew Williams, *PTAB Update – The Board Grants Its Second Motion to Amend (At Least in Part)*, PATENT DOCS (Jan. 8, 2015), <http://www.patentdocs.org/2015/01/ptab-update-the-board-grants-its-second-motion-to-amend-at-least-in-part.html>; *see also* Jennifer E. Hoekel, *PTAB Grants First Opposed Motion to Amend Claims – Patent Trial and Appeal Board*, THE NATIONAL LAW REVIEW (Jan. 14, 2015), <http://www.natlawreview.com/article/ptab-grants-first-opposed-motion-to-amend-claims-patent-trial-and-appeal-board>.

(statement of Sen. Leahy) (the purpose is to “decrease[] the likelihood of expensive litigation because it creates a less costly, in-house administrative alternative to review patent validity claims”). By refusing to apply to Inter Partes Review the procedural and substantive law of the district courts, the panel majority defeats the legislative purpose, for the PTO tribunal cannot serve as a surrogate for district court litigation if the PTAB does not apply the same law to the same evidence.

Second, and as a further departure from the legislative plan, the panel majority holds that the “final and nonappealable” statutory provision relating to whether to institute Inter Partes Review means that “§ 314(d) . . . must be read to bar review of all institution decisions, even after the Board issues a final decision.” Maj. op. at 7. Does this mean that such decisions can never be judicially reviewed, even if contrary to law, even if material to the final appealed judgment? This ruling appears to impede full judicial review of the PTAB’s final decision, further negating the purpose of the America Invents Act to achieve correct adjudication of patent validity through Inter Partes Review in the administrative agency.

Several other aspects of the America Invents Act are incorrectly or confusingly treated. For example, as Cuozzo points out, here the PTAB decision relies on arguments and evidence that had not been raised in the petition to institute, although the statute requires that all arguments and evidence must be presented in the petition. The panel majority holds that “[t]he fact that the petition was defective is irrelevant because a proper petition could have been drafted.” Maj. op. at 8. Such broad and conflicting departure from the statutory provisions cannot have been intended.

Inter Partes Review is intended as a far-reaching and powerful surrogate for district court validity determinations. The plan is that an adversarial proceeding in the

PTO will resolve most issues of patent validity, without the disruption and expense and delay of district court litigation. I write in dissent because the court today moves Inter Partes Review in directions contrary to the language and intent of the America Invents Act, thereby impeding its purpose to serve as a surrogate for district court litigation.

I

Inter Partes Review as surrogate for district court litigation

The goal of Inter Partes Review is to rehabilitate the innovation incentive, by reinforcing valid patents and eliminating invalid patents through an expeditious and cost-effective alternative to litigation, on whose results the innovation community can rely. To this end, the new Inter Partes Review proceedings provide for discovery, expert testimony, depositions, subpoenas, briefs, and oral argument by adversaries. *See Abbott Labs. v. Cordis Corp.*, 710 F.3d 1318, 1326 (Fed. Cir. 2013) (the America Invents Act created an adversarial proceeding as in the district courts, where all appropriate evidence can be adduced).

Inter Partes Review is limited to patent validity, for validity is a central issue in patent litigation, and often is dispositive of the entire litigation. To serve as a reliable substitute for district court validity determination, the legislation was designed to achieve the same correct decision as would be obtained in a district court on the same evidence and the same law. However, this court holds that PTAB adjudication need not conform to the law and consider the same evidence as in the courts. Instead, the panel majority authorizes the PTAB to employ the expedients and shortcuts that were developed for the give-and-take of examination and reexamination, instead of determining validity as a matter of fact and law, as required in the courts.

Although the PTAB is authorized to apply trial and evidentiary procedures, my colleagues hold that the PTAB need not apply the same rules of law and evidence as in the district courts. It is critical to the success of Inter Partes Review that it serve its purpose as a district court surrogate, yet it is not disputed that the “broadest reasonable interpretation” of claims and technology can differ from the ultimately correct decision on the standards of *Phillips v. AWH Corp.*, 45 F.3d 1303 (Fed. Cir. 2005) (en banc). This built-in discrepancy defeats the legislative purpose of substituting administrative adjudication for district court adjudication, for a PTAB decision based on this artificial “broadest” standard cannot substitute for litigation directed to the correct result.

A

My colleagues argue that Inter Partes Review is simply a reexamination of the patent, and thus should be conducted on the same broadest reasonable interpretation as for reexamination. This argument is negated by the heavy legislative emphasis on differences from reexamination as achieved by these new procedures.

The House Report states that the America Invents Act “converts” Inter Partes Reexamination “from an examinational proceeding to an adjudicative proceeding.” H.R. Rep. No. 112-98, pt. 1, at 46 (2011); *see also id.* at 75 (describing post-grant review and Inter Partes Review as “adjudicative systems”). The Report further explains:

Unlike reexamination proceedings, which provide only a limited basis on which to consider whether a patent should have issued, the post-grant review proceeding permits a challenge on any ground related to invalidity under section 282. The intent of the post-grant review process is to enable early challenges to patents The Committee believes that this new, early-stage process for challenging patent validity . . . will

make the patent system more efficient and improve the quality of patents and the patent system.

Id. at 46. It is undisputed that Congress intended that Inter Partes Review would differ from examination or reexamination, and that these new proceedings would be adjudicative, like the validity proceedings in the district courts. In the PTAB's words, "[a]n inter partes review is neither a patent examination nor a patent reexamination," but is "a trial, adjudicatory in nature [which] constitutes litigation." *Google Inc. v. Jongerius Panoramic Techs., LLC*, IPR2013-00191, Paper No. 50, at 4 (PTAB Feb. 13, 2014).

To implement the intent of the America Invents Act, the administrative judges of the PTAB must apply the same procedural and substantive law as the district courts. By adopting the examination protocol of broadest reasonable interpretation, the PTO and the panel majority negate the legislative purpose, for the PTAB tribunals cannot serve as a surrogate for district court litigation if the PTAB does not apply the same law to the same evidence. Instead, Inter Partes Review will merely become another mechanism for delay, harassment, and expenditure, despite the Congressional warning:

While this amendment is intended to remove current disincentives to current administrative processes, the changes made by it are not to be used as tools for harassment or a means to prevent market entry through repeated litigation and administrative attacks on the validity of a patent. Doing so would frustrate the purpose of the section as providing quick and cost effective alternatives to litigation.

H.R. Rep. No. 112-98, pt. 1, at 47 (2011).

The broadest reasonable interpretation standard is not a rule of law, but a pragmatic protocol applied in patentability examination and reexamination. See *In re Yamamoto*, 740 F.2d 1569, 1571 (Fed. Cir. 1984) (giving claims their broadest reasonable interpretation “serves the public interest by reducing the possibility that claims, finally allowed, will be given broader scope than is justified”); see also, e.g., *In re Hyatt*, 211 F.3d 1367, 1372 (Fed. Cir. 2000); *In re Zletz*, 893 F.2d 319, 322 (Fed. Cir. 1989). The broadest reasonable interpretation is an examination expedient, not a canon of construction. It serves not to state the correct meaning of the claim, but to provide a framework for clarification and amendment.

Contrary to the panel majority’s theory, the differences between reexamination and the new post-grant proceedings are very relevant to Inter Partes Review. The standard for adjudication of validity is set forth in *Phillips v. AWH Corp.*, where claims are given their correct construction as understood by a person of ordinary skill in the field of the invention. Adoption of a broadest interpretation renders the PTAB rulings legally unreliable, leaving the parties to district court proceedings, whatever the decision of the PTAB. That was not the legislative plan.

B

The panel majority holds that it is irrelevant that the America Invents Act does not mention a “broadest reasonable interpretation” standard, stating that endorsement of this approach is “implicit” in the legislative silence. Maj. op. at 16. To the contrary, the language of the America Invents Act demonstrates that Congress did not intend that the PTAB tribunals would construe claims differently from the district courts.

While the reexamination, interference, and reissue statutes and regulations refer to the “patentability” of a claim, 35 U.S.C. §§ 305; 135; 37 C.F.R. § 1.97, the term

“validity” is used throughout the Inter Partes Review statute. 35 U.S.C. § 316. The distinction is carefully made in the statute, for “validity” is the province of adjudication, while “patentability” applies to examination. *See In re Donaldson Co., Inc.*, 16 F.3d 1189, 1193 (Fed. Cir. 1994) (referring to “a patentability determination in the PTO or . . . a validity or infringement determination in a court”). This distinction is significant.

The America Invents Act refers to the “proper meaning of a patent claim,” *see* 35 U.S.C. §301(d) (referring to “the proper meaning of a patent claim in a proceeding that is ordered or instituted pursuant to section 304, 314, or 324”). The “proper meaning of a patent claim” is the correct meaning. Correctness is the province of the courts, and correctness is the purpose of Inter Partes Review.

C

The panel majority further argues that the Federal Circuit has “approved” the “broadest reasonable interpretation” standard in “a variety of [PTO] proceedings.” *Maj. op.* at 13. Indeed we have, explaining in *In re Yamamoto* that the expedient of broad interpretation during examination and reexamination is based on the ready ability to amend claims, the *Yamamoto* court stressing this difference from judicial proceedings:

An applicant’s ability to amend his claims to avoid cited prior art distinguishes proceedings before the PTO from proceedings in federal district courts on issued patents. When an application is pending in the PTO, the applicant has the ability to correct errors in claim language and adjust the scope of claim protection as needed. This opportunity is not available in an infringement action in district court.

740 F.2d at 1572.

In routine examination and reexamination, the amendment of a claim is a fluid, back-and-forth process between an examiner and the applicant, who may present proposed amendments and new claims. Reexamination is “conducted according to the procedures established for initial examination under the provisions of Sections 132 and 133.” 35 U.S.C. § 305. The focus of reexamination proceedings “returns essentially to that present in an initial examination.” *In re Etter*, 756 F.2d 852, 857 (Fed. Cir. 1985). It is significant that when claims in reexamination are not eligible for amendment, as when a patent has expired, the PTO instructs examiners not to use the broadest reasonable interpretation. MPEP § 2258 G states:

In a reexamination proceeding involving claims of an expired patent, claim construction pursuant to the principle set forth by the court in *Phillips v. AWH Corp.*, 415 F.3d 1303, 1316 (Fed. Cir. 2005) (words of a claim “are generally given their ordinary and customary meaning” as understood by a person of ordinary skill in the art in question at the time of the invention) should be applied since the expired claims are not subject to amendment.

The panel majority is incorrect in stating that Inter Partes Review proceedings are “not materially different” from pre-AIA proceedings with respect to the opportunity to amend. Maj. op. at 15.

It is reported that the ability to amend claims in Inter Partes Review proceedings, as administered by the PTO, is almost entirely illusory. Amendment requires permission, 37 C.F.R. § 42.20(b), and to date motions to amend have been granted in only two cases, *see supra* note 1. Patent owners are limited to “one motion to amend,” and are presumptively limited to substituting one issued claim for one amended claim. 37 C.F.R. § 42.221(a)(3). Additional motions to amend are allowed only “to materially

advance the settlement of a proceeding” or “as permitted by regulations prescribed by the Director.” 35 U.S.C. § 316(d)(2).

It is beyond debate that Inter Partes Review does not allow the kind of iterative amendment process that initially justified adoption of a “broadest reasonable interpretation” protocol in examination and reexamination.

D

The panel majority states that the PTO is acting within its rulemaking authority. The Supreme Court has stated that “although an agency’s interpretation of the statute under which it operates is entitled to some deference, ‘this deference is constrained by our obligation to honor the clear meaning of a statute, as revealed by its language, purpose, and history.’” *Se. Cmty. Coll. v. Davis*, 442 U.S. 397, (1979) (quoting *Teamsters v. Daniel*, 439 U.S. 551, 566 n. 20 (1979)); *see also Muwwakkil v. Office of Pers. Mgmt.*, 18 F.3d 921, 925 (Fed. Cir. 1994) (“When an agency’s interpretation of a statute it is entrusted to administer is contrary to the intent of Congress, as divined from the statute and its legislative history, we owe it no deference.”).

In promulgating 37 C.F.R. § 42.300(b), the PTO departed from the purpose of the America Invents Act to create a reliable substitute for district court litigation. The invocation of the “broadest” construction rather than the correct construction is inconsistent with the language, purpose and history of the America Invents Act. Regulations must implement the statute they seek to serve, not defeat it. *See Ernst & Ernst v. Hochfelder*, 425 U.S. 185, 213–14 (1976) (“The rulemaking power granted to an administrative agency charged with the administration of a federal statute is not the power to make law. Rather, it is the power to adopt regulations to carry into effect the will of Congress as expressed by the statute.”). Pending potential legislative action, it is our

obligation to interpret the statute in accordance with its legislative purpose.²

In sum, the procedure whereby claims are given their broadest reasonable interpretation instead of their correct construction defeats the purpose of Inter Partes Review as a surrogate for district court litigation.

II

The nonappealable decision to institute Inter Partes Review

The America Invents Act states that the PTO's decision whether to institute Inter Partes Review is "final and nonappealable." 35 U.S.C. § 314(d). The panel majority holds that this means that rulings in connection with the institution of Inter Partes Review, whether review is granted or denied, cannot be appealed to any court, either by interlocutory appeal or on appeal of final judgment. That is not what the statute states, or requires.

The panel majority "conclude[s] that § 314(d) prohibits review of the decision to institute IPR even after a final decision. On its face, the provision is not directed to

² On December 5, 2013, the House passed H.R. 3309, amending section 316(a) to state that in Inter Partes Review "each claim of a patent shall be construed as such claim would be in a civil action to invalidate a patent under section 282(b), including constructing each claim of the patent in accordance with the ordinary and customary meaning of such claim as understood by one of ordinary skill in the art and the prosecution history pertaining to the patent" H.R. Rep. No. 113-279, at 13-14 (2013). The corresponding Senate bill was reported to have stalled for reasons unrelated to this section. This proposed clarification is further evidence of legislative intent.

precluding review only before a final decision. It is written to exclude all review of the decision whether to institute review.” Maj. op. at 6. On this conclusion, the panel majority holds that we are barred by § 314(d) from reviewing compliance with the statutory limits of Inter Partes Review.

The majority acknowledges that situations may arise “where the PTO has clearly and indisputably exceeded its authority,” and suggests that possibly “mandamus may be available to challenge the PTO’s decision to grant a petition to institute IPR after the Board’s final decision.” Maj. op. at 8. This hint is disputed by the PTO, pointing to the Federal Circuit’s strict requirements for mandamus.

The ultimate authority regarding what a statute says and how it applies is the judiciary. The purpose of the “nonappealable” provision apparently is to bar interlocutory proceedings and harassing filings by those seeking to immobilize the patent or exhaust the patentee. The bar of interlocutory appeals is routine. However, sensitive scrutiny is required, not blanket enlargement for all circumstances. In *Bowen v. Michigan Academy of Family Physicians*, 476 U.S. 667 (1986) the Court explained that “[f]rom the beginning ‘our cases [have established] that judicial review of a final agency action by an aggrieved person will not be cut off unless there is persuasive reason to believe that such was the purpose of Congress.’” *Id.* at 670 (alteration in original) (quoting *Abbott Labs. v. Gardner*, 387 U.S. 136, 140 (1967)).

Cuozzo points out that here the PTAB decision relies on arguments that had not been raised in the petition for review, contrary to the requirements of the statute. 35 U.S.C. § 312(a)(3) (the petition must identify the grounds and evidence as to each challenged claim). The panel majority holds that “[t]he fact that the petition was defective is irrelevant because a proper petition could have

been drafted.” Maj. op. at 8. Is this prohibited appellate review of the nonappealable petition? Or simply a curious departure from the fundamental rule of administrative action, that agency decisions must be reviewable on appeal? In *Block v. Community Nutrition Institute*, 467 U.S. 340 (1984), the Court elaborated on the principle of judicial review of agency determinations. The Court summarized:

Whether and to what extent a particular statute precludes judicial review is determined not only from its express language, but also from the structure of the statutory scheme, its objectives, its legislative history, and the nature of the administrative action involved.

Id. at 345.

The statute requires thoughtful adjustment to the legislative purpose, not heavy-handed foreclosure of all review of anything related to the petition.

Conclusion

The America Invents Act has the purpose of “providing quick and cost effective alternatives to litigation.” H.R. Rep. No. 112-98, pt. 1, at 48 (2011). The PTO is authorized to review the validity of issued patents in accordance with new procedures, to reach the correct decision, but faster, cheaper, and sooner than in the district court. The panel majority fails to implement the statutory purpose.